

# DMX Signal Amplifier

Model No.: DA-L

2 Channel/Photo-electricity insulation

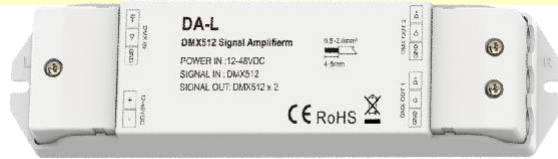

CE RoHS LVD

## Features

- One DMX512 signal input, two DMX512 signal output.
- Dedicated to amplifying, distribute and insulate the signal that comes from the lighting system equipment when it is connected to the bus of DMX512(or RS-485).
- Realize extending the signal transmission distance.
- Signals expansion output control, increase DMX (485) signal amplifier to distribute multi-channel control.
- Photo-electricity insulation between input and output terminals, output terminals among channels, so as to avoid the expensive equipment such as light, 485 communications equipment, DMX driver, precise digital lighting controller, being burnt by the possible high voltage which caused from the wrong wire connection and a broken equipment, also can avoid the signal interference between each DMX equipment.

## Technical Parameters

Input and Output	
Input voltage	12-48VDC
Input current	0.5A Max.
Input signal	DMX512
Output signal	DMX512 x 2

Safety and EMC	
EMC standard (EMC)	ETSI EN 301 489-1 V2.2.3 ETSI EN 301 489-17 V3.2.4
Safety standard (LVD)	EN 62368-1:2020+A11:2020
Certification	CE, EMC, LVD

Environment	
Operation temperature	Ta: -30°C ~ +55°C
Case temperature (Max.)	Tc: +65°C
IP rating	IP20

Warranty and Protection	
Warranty	5 years
Protection	Reverse Polarity

Weight	
Net weight	0.095kg
Gross weight	0.125kg

## Mechanical Structures and Installations

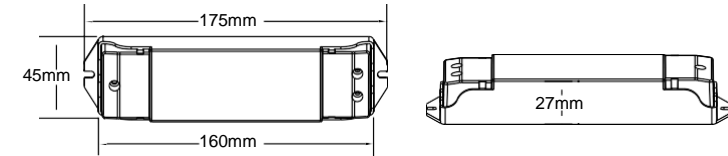
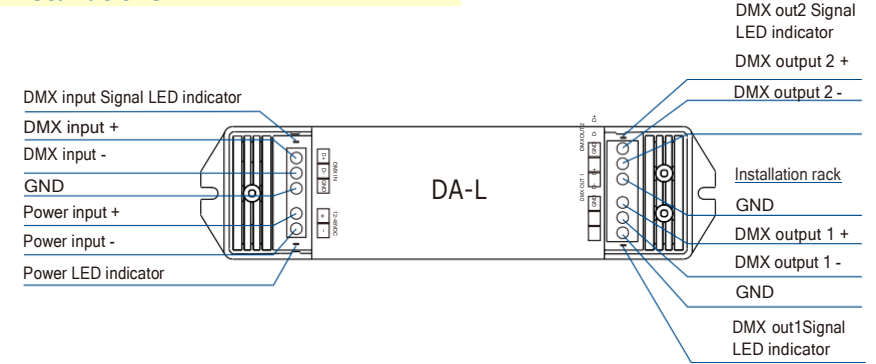

**Wiring Diagram**

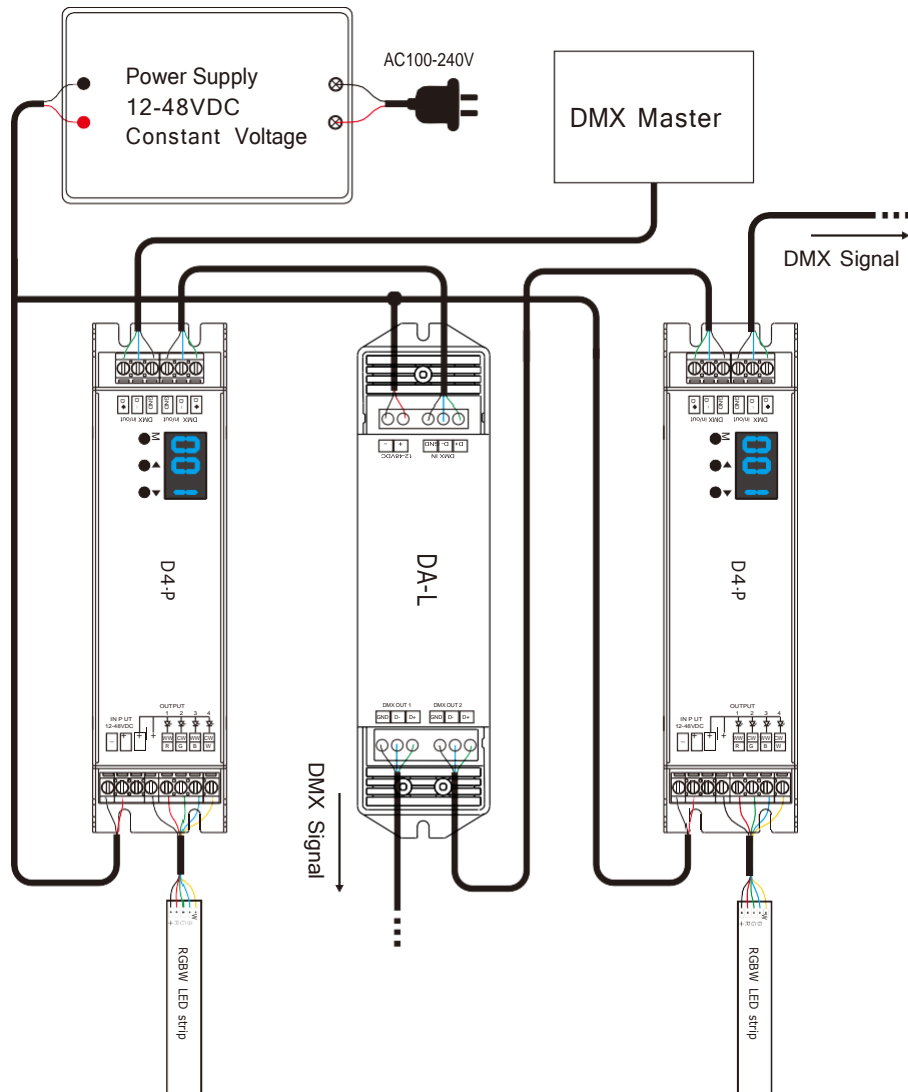

**Note:**

1. An amplifier is needed when more than 32 decoders are connected, signal amplification should not be more than 5 times continuously.
2. If the recoil effect occurs because of longer signal line or bad line quality, please try to connect 0.25W 90-120Ω terminal resistor at the end of each line.

**A. The signal of many of DMX LED lights connection example:**

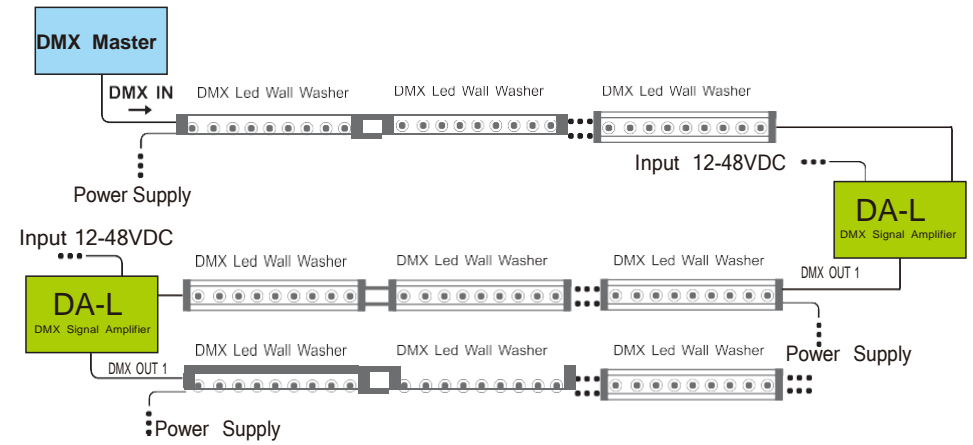

**B. The long distance of DMX signal example:**

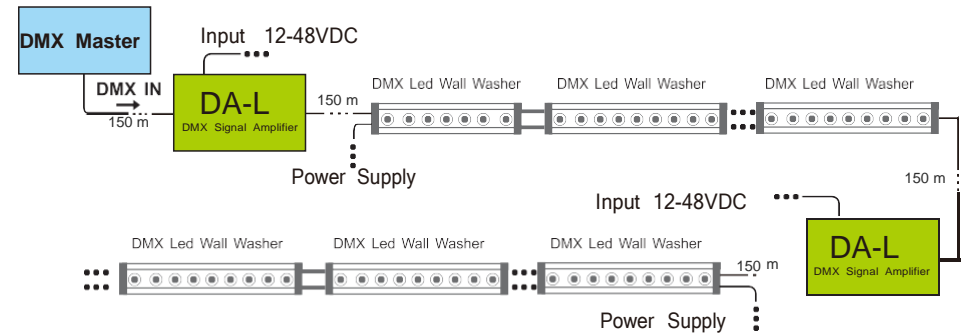

**C. The distribution of DMX signal example:**

