

AC Triac RF + Push Dimmer

Model No.: TR1

RF dimming/Numeric display/Leading edge or trailing edge/Min brightness settable/Push Dim/Din rail

Features

- RF + Push AC phase-cut dimmer, 1 channel output.
- To dim and switch single color dimmable LED lamps, traditional incandescent and halogen lights.
- Digital numeric display, set brightness by buttons.
- 0-100% dimming smoothly without any flash.
- Reverse-phase dimming or forward-phase dimming selectable.
- Minimum brightness set from 1% to 40%.
- Light on/off fade time 0 - 20s selectable.
- Compatibility with RF 2.4G single zone or multiple zones dimming remote control.
- Connect with external push switch to achieve on/off and 0-100% dimming function.
- Over-heat protection, recover automatically.
- Available in white or black.



CE LVD RoHS EMC

Technical Parameters

Input and Output		Dimming data	
Input voltage	100-240VAC	Input signal	3 Buttons RF 2.4GHz AC Push
Output voltage	100-240VAC	Dimming level	100 levels
Output current	1CH, 2A	Dimming range	0-100%
Output power	200-480W	Environment	
Safety and EMC		Operation temperature	Ta: -30°C ~ +55°C
EMC standard (EMC)	ETSI EN 301 489-1 V2.2.3 ETSI EN 301 489-17 V3.2.4	Case temperature (Max.)	Tc: +85°C
Safety standard (LVD)	EN 62368-1:2020+A11:2020	IP rating	IP20
Radio Equipment (RED)	ETSI EN 300 328 V2.2.2	Warranty	
Certification	CE, EMC, LVD, RED	Warranty	5 years

Compatible Load Types

Load Type	Maximum Load	Remarks
Dimmable LED lamps	300W @ 220V 150W @ 110V	Due to variety of LED lamp designs, maximum number of LED LAMPs is further dependent on power factor result when connected to dimmer.
Triac Dimmable LED drivers	300W @ 220V 150W @ 110V	Maximum permitted number of drivers is 300W divided by driver nameplate power rating, and make sure the surge current is no more than 2 times 65A.
Incandescent lighting, HV Halogen lamps	500W @ 220V 250W @ 110V	

Mechanical Structures and Installations

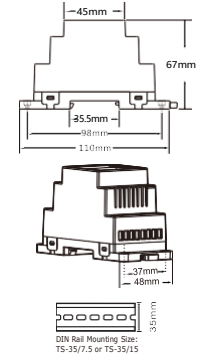
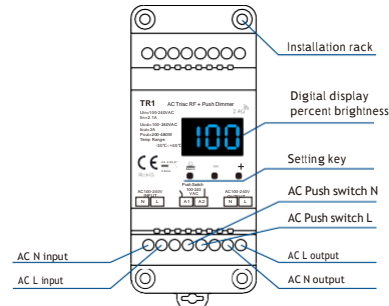

Wiring Diagram

Caution: Please carefully ensure all wire connections and polarities are correct and secure before applying power, otherwise this controller will be damaged.

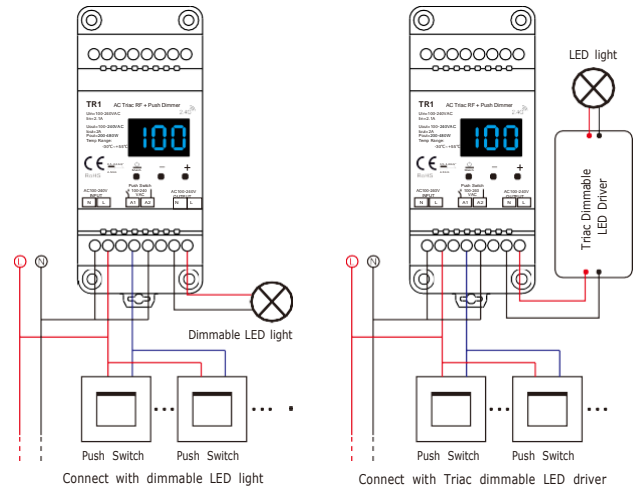

System parameter setting

- Long press \odot and - key for 2s, prepare for setup system parameter: control method, minimum brightness curve, light on/off fade time, automatic blank screen, short press \odot key to switch four item.
- Control method: short press - or + key to switch forward-phase("C-F") or reverse-phase("C-R").

Forward-phase control dimmer

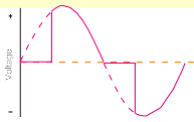

Reverse-phase control dimmer

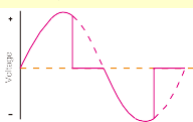

- Minimum brightness: short press - or + key to set minimum brightness, from 1% to 40%("b01" to "b40"). You need set suitable minimum brightness to avoid flick.
- Light on/off fade time: short press - or + key to switch 0.5s("d00"), 2s("d02"), 3s("d03"), 5s("d05"), 10s("d10") or 20s("d20") fade on/off time.
- Automatic blank screen: short press - or + key to switch enable("bon") or disable("boF") automatic blank screen.
- Long press M key for 2s or timeout 10s, quit system parameter setting.

Restore factory default parameter

- Long press - and + key for 2s, restore factory default parameter, display "RES".
- Factory default parameter: 100% brightness, reverse-phase control, 5% minimum brightness, 0.5s fade on/off time, disable automatic blank screen.

Dimming by 3 buttons

- Short press \odot key, turn on or turn off light.
When display percent brightness value (001-100), the light is on.
When display "bon", the light is off.
- When light is on, Press - or + key to change brightness, long press for continuous adjustment.

Dimming by Push switch

The provided AC Push-Dim interface allows for a simple dimming method using commercially available non-latching (momentary) wall switches.

- Short press:
Turn on or off light.
- Long press (1-6s):
Press and hold to step-less dimming,
With every other long press, the light level goes to the opposite direction.
- Dimming memory:
Light returns to the previous dimming level when switched off and on again, even at power failure.
- Synchronization:
If more than one dimmer are connected to the same push switch, do a long press for more than 10s, then the system is synchronized and all lights in the group dim up to 100%.
This means there is no need for any additional synchrony wire in larger installations.
We recommend the number of dimmers connected to a push switch does not exceed 25 pieces,
The maximum length of the wires from push to dimmer should be no more than 20 meters.

Dimming by RF remote

Match Remote Control (two match ways)

End user can choose the suitable match/delete ways. Two options are offered for selection:

Use the Match key

Match:
Long press Match key for 2s, display "RLS", within 5s, press on/off key (single zone remote) or zone key (multiple zone remote) of the remote, display "RLO", match is successful.

Delete:
Long press Match key for 5s, until display "RLS", delete all matched remote.

Use Power Restart

Match:
Switch off the power, then switch on power, repeat again. Immediately short press on/off key (single zone remote) or zone key (multiple zone remote) 3 times on the remote. The light blinks 3 times means match is successful.

Delete:
Switch off the power, then switch on power, repeat again. Immediately short press on/off key (single zone remote) or zone key (multiple zone remote) 5 times on the remote. The light blinks 5 times means all matched remotes were deleted.

RF remote application notes

1. All the receivers in the same zone.

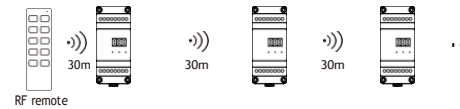

RF remote

Auto-transmitting: One receiver can transmit the signals from the remote to another receiver within 30m, as long as there is a receiver within 30m, the remote-control distance can be extended.

Auto-synchronization: Multiple receivers within 30m distance can work synchronously when they are controlled by the same remote.

Receiver placement may offer up to 30m communication distance. Metals and other metal materials will reduce the range.

Strong signal sources such as WiFi routers and microwave ovens will affect the range.

We recommend for indoor applications that receiver placements should be no further apart than 15m.

2. Each receiver (one or more) in a different zone, like zone 1, 2, 3 or 4.

