

## AC Triac DMX Dimmer

Model No.: S1-DR

2 Channel / RDM / Stand-alone function / Leading edge or trailing edge / Numeric display / Din rail

### Features

- AC phase-cut mosfet dimmer with DMX512 function, two channel output.
- Comply with the DMX512 standard protocols.
- Digital numeric display, set DMX decode start address by buttons.
- RDM function can realize intercommunication between DMX master and decoder.
- 1/2 DMX channel output selectable.
- Reverse-phase dimming or forward-phase dimming selectable.
- Minimum brightness set from 1% to 40%.
- Stand-alone dynamic mode and 2 channel dimmer mode selectable, which be controlled by buttons with built-in programs, instead of DMX signal.
- To dim and switch single color dimmable LED lamps, traditional incandescent and halogen lights.
- Over-heat protection, recover automatically.
- Available in white or black.



### Technical Parameters

CE RoHS EMC LVD

| Input and Output     |   | Dimming data            |                   |
|----------------------|---|-------------------------|-------------------|
| Input voltage        | 100-240VAC  | Input signal            | DMX512            |
| Output voltage       | 2 x (100-240)VAC                                      | Dimming level           | 256 levels        |
| Output current       | 2CH, 1.5A/CH  | Dimming range           | 0-100%            |
| Output power         | 2 x (150-360)W  | Environment             |                   |
| Safety and EMC       |   | Operation temperature   | Ta: -30°C ~ +55°C |
| EMC standard (EMC)   | ETSI EN 301 489-1 V2.2.3<br>ETSI EN 301 489-17 V3.2.4 | Case temperature (Max.) | Tc: +85°C         |
| Safety standard(LVD) | EN 62368-1:2020+A11:2020                              | IP rating               | IP20              |
| Certification        | CE,EMC,LVD  | Warranty                |                   |
|                      |   | Warranty                | 5 years           |
|                      |   | Weight                  |                   |
|                      |   | Net weight              | 0.131kg           |
|                      |   | Gross weight            | 0.161kg           |

### Compatible Load Types

| Load Type                               | Maximum Load               | Remarks  |
|---|----------------------------|--|
| Dimmable LED lamps                      | 200W @ 220V<br>100W @ 110V | Due to variety of LED lamp designs, maximum number of LED lamps is further dependent on power factor result when connected to dimmer.              |
| Triac Dimmable LED drivers              | 200W @ 220V<br>100W @ 110V | Maximum permitted number of drivers is 200W divided by driver nameplate power rating, and make sure the surge current is no more than 2 times 65A. |
| Incandescent lighting, HV Halogen lamps | 400W @ 220V<br>200W @ 110V |  |

### Mechanical Structures and Installations

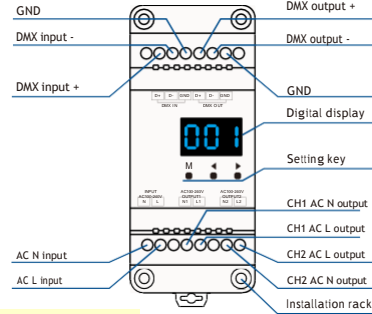

### Wiring Diagram

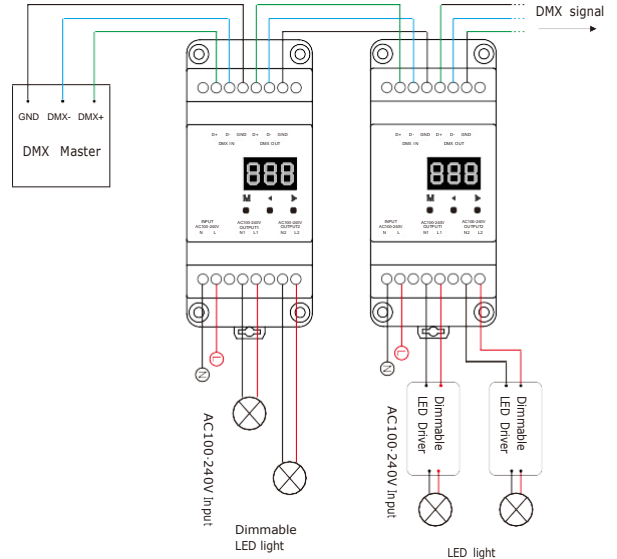

## ⚠ Caution:

Please carefully ensure all wire connections and polarities are correct and secure before applying power, otherwise this controller will be damaged.

Note: When calculating the maximum number of load lamps or drivers, the input power or input current parameters of a single lamp or driver must be used, the output power parameters can not be used. In addition, the maximum surge current of the dimmer is 65A, the sum of surge current of multiple dimmable LED drivers should not exceed 2 times. otherwise, the product will be overloaded and damaged.

## Operation

### System parameter setting

- Long press M and ◀ key for 2s, prepare for setup system parameter: decode mode, control method, default output level, minimum brightness curve, automatic blank screen. short press M key to switch five item.
- Decode mode: short press ◀ or ▶ key to switch one-channel decode("d-1") or two-channel decode("d-2"). When set as 1 channel decode, the decoder occupy only 1 DMX address, and two channel output the same brightness of this DMX address.
- Control method: short press ◀ or ▶ key to switch forward-phase("C-F") or reverse-phase("C-R").

Forward-phase control dimmer

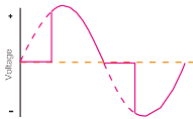

Reverse-phase control dimmer

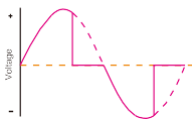

- Minimum brightness: short press ◀ or ▶ key to set minimum brightness, from 1% to 40%("b01" to "b40"). You need set suitable minimum brightness to avoid flick.
- Default output level: press ◀ or ▶ key to change default 0-100% level ("d00" to "dFF" ) when no DMX input signal.
- Automatic blank screen: short press ◀ or ▶ key to switch enable("bon") or disable("boF") automatic blank screen.
- Long press M key for 2s or timeout 10s, quit system parameter setting.

### DMX mode

- Short press M key, when display 001-512, enter DMX mode.
- Press ◀ or ▶ key to change DMX decode start address(001-512), long press for fast adjustment.
- If there is a DMX signal input, will enter DMX mode automatically.
- DMX Dimming: Each S1-DR DMX decoder occupy 2 DMX address when connecting the DMX console.



DMX mode  
(001~512)

For example, the defaulted start address is 1, their corresponding relationship in the form:

| DMX Console | DMX Decoder Output |
|-------------|--------------------|
| CH1 0-255   | CH1 0-100%         |
| CH2 0-255   | CH2 0-100%         |

### Stand-alone dimmer mode

- Short press M key, when display L-1~L-8, enter stand-alone dimmer mode.
- Press ◀ or ▶ key to change dimmer mode number(L-1~L-8).
- Each dimmer mode can adjust each channel brightness independently. Long press M key for 2s, prepare for setup two channel brightness. Short press M key to switch two channel (100-1FF; 200-2FF). Press ◀ or ▶ key to setup brightness value of each channel. Long press M key for 2s, or timeout 10s, quit setting.
- Enter stand-alone dimmer mode only when DMX signal is disconnected or lost.



Stand-alone dimmer mode  
(L-1~L-8)

### Stand-alone dynamic mode

- Short press M key, when display P-1~P-4, enter stand-alone dynamic mode.
- Press ◀ or ▶ key to change dynamic mode number(P-1~P-4).
- Each mode can adjust speed and brightness. Long press M key for 2s, prepare for setup mode speed, brightness. Short press M key to switch two item. Press ◀ or ▶ key to setup value of each item. Mode speed: 1-10 level speed (S-1, S-9, S-F). Mode brightness: 1-10 level brightness (b-1, b-9, b-F). Long press M key for 2s, or timeout 10s, quit setting.
- Enter stand-alone dynamic mode only when DMX signal is disconnected or lost.



Stand-alone dynamic mode  
(P-1~P-4)



Speed  
(8 level)



Brightness  
(10 level,100%)

### Dynamic mode list

| No. | Name                                       |
|-----|--|
| P-1 | 2ch light on/off synchronously             |
| P-2 | 2ch single light on/off in sequence        |
| P-3 | 2ch light fadein and fadeout synchronously |
| P-4 | 2ch light fadein and fadeout in sequence   |

### Restore factory default parameter.

- Long press ◀ and ▶ key for 2s, restore factory default parameter, display "RES".
- Factory default parameter: DMX decode mode, DMX decode start address is 1, two channel decode, reverse-phase control, 10% minimum brightness, dimmer mode number is 1, dynamic mode number is 1, output 100% level when no DMX input, disable automatic blank screen.